

ACCURL PRODUCT RANGE:

EUROMASTER
Medium sizes

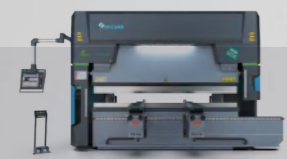

EB ULTRA
SMALL sizes



MASTERLINE
ALL sizes



TUBELINE
ALL sizes



ES NT-30T



HANDHELD LASER
WELDING TECHNOLOGY



100%
Electrical Press Brakes
▶▶ NEXT



Shaping your future

ACCURL MACHINE TOOLS
ANHUI | CHINA

Industrial Park in Bowang Special
Economic Zone Maanshan
Anhui | China

T | +86 0555 2780563
M | +86-188 5555 1088
E | info@accurl.com

ACCURL.com

LOCAL DEALER:

SUSTAINABLE BENDING SOLUTIONS

Bending ... has never been easier.

EB ULTRA

SERVO-ELECTRIC SYNCHRONIZATION

ACCURL eB Ultra model is fully electric. It uses the SYNCHRO technology to control two servo-electric axes in bending control, thus being able to compensate Y1 and Y2 axes independently.



WARRANTY*
5 YEARS
ACCURL

DON'T SETTLE
FOR A STANDARD PRESS BRAKE,
CHOOSE A SUPER-CUSTOMIZATION

Your production is unique,
and your tools must be made to measure.

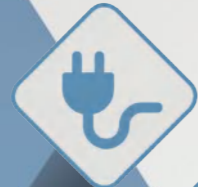

100% Fully electric



Over 55% higher
productivity



Uses up to 85%
less energy,
less CO2 emission



No harmful
hydraulic oil



High degree
of noise reduction

STANDARD

- > DELEM® DA60 SERIES Controller
- > DELEM® Profile Offline Software
- > Connection to company LAN and ERP
- > 520mm* Daylight
- > 270mm* Beam Stroke
- > LAZERSAFE Systems IRIS Block Laser*
- > ACCURL BGA-4 for X=450mm X,R,Z1,Z2-Axis
- > ACCURL® "WILA WAVE" WEDGE ULTRA CNC Crowning Table*
- > Main Characteristics:
 - Bending accuracy: 2,5μ
 - Approach speed: 180~220mm/s
 - Return speed: 180mm/s
 - Bending speed: 10/20*mm/s
- > ACCURL® Products management (scanner barcode reader*)
- > ACCURL® Pneumatic upper Clamping AIR SYSTEM PN
- > ACCURL® SMART INNOVATION Industry 4.0



AVAILABLE
FEATURES
AND OPTIONALS



100% FULLY-ELECTRIC SERVO TECHNOLOGY

The synchro servo-electric system offers an effective profitability increase, more user-friendly, precision and comfort.

Speed More than 220mm/s

BENEFITS COMPARED TO A TRADITIONAL PRESS

Energy consumption:	-85%
Automatic standby:	Start and stop
During programming and bending:	Zero consumption
Oil duration:	NO Oil
Productivity for reduced cycle times:	+55%

Expanded CNC to view consumption in real time and estimate production costs

AFFORDABLE TECHNOLOGY

ACCURL New eB Ultra is a fully electric machine is inte-grated with the highest technology coupled with a friendly use, the transmission components are high and suitable for high loads.



Start-Stop

roda tem que ter menos 1%

eB Ultra
NEXT

- | Energy saving
- | Precise bending results
- | Same consistency in each cycle
- | Minimum tool change and adjustment time
- | Maximum speed and safety

Manufacturing Efficiency, Energy efficiency, Ergonomics:

The components used in the mechanical transmission, ensures high durability while maintaining accuracy over time.

The innovative, modular design of the eB Ultra Series has been achieved through adept engineering methods, collective industry experience, and high-standard manufacturing processes.

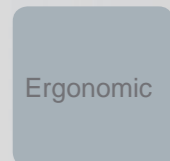
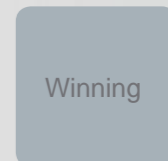
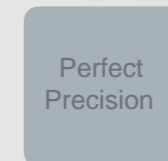
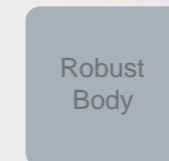
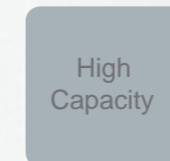

INNOVATION WITH THE E FOR EFFICIENCY

This press brake is integrated with the highest technology coupled with a friendly use. This model is a top machine that guarantees high precision and competitiveness.

-80%
ENERGY CONSUMPTION

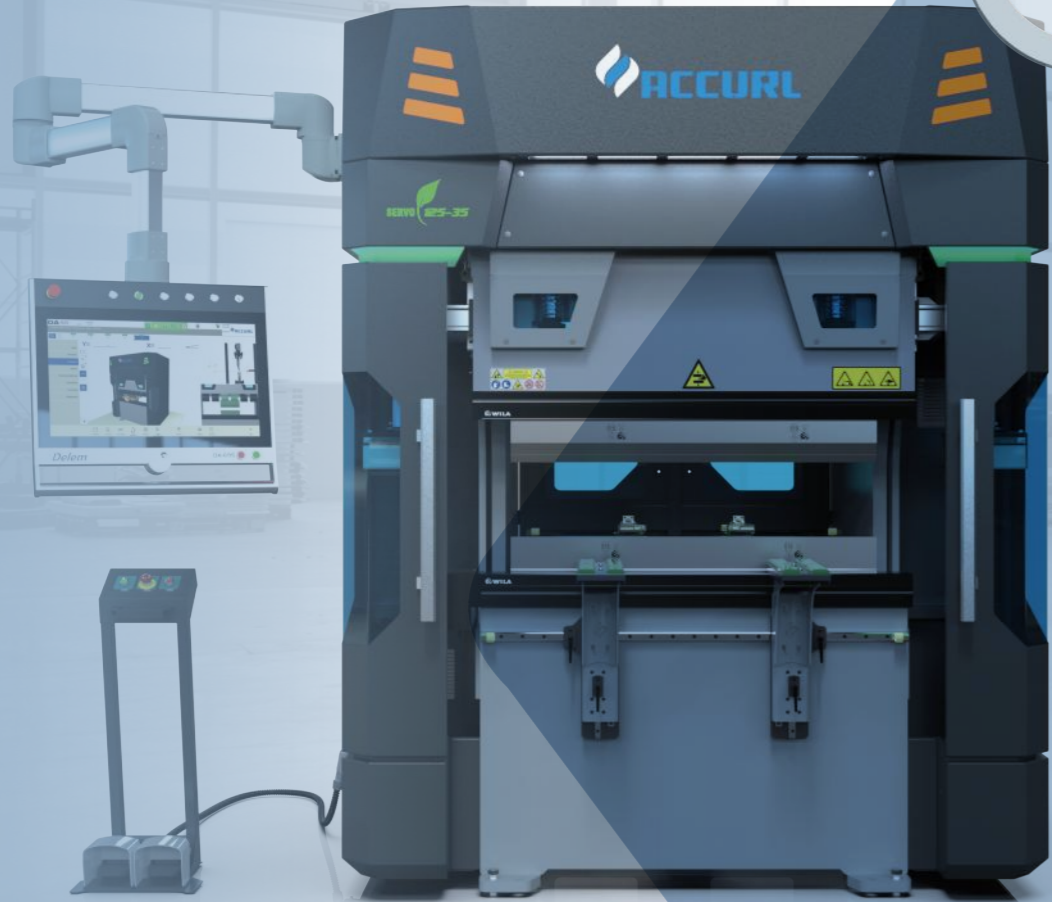

RapidBend can improve machine performance and efficiency by up to 72% to significantly enhance your productivity.

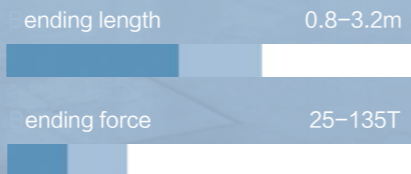

HIGH RELIABILITY AND MAXIMUM PRODUCTIVITY

So, New eB Ultra is possible to guarantee better performance and durability, reducing unwanted effects caused by inertia. and this model is a top machine that guarantees high precision and competitiveness.

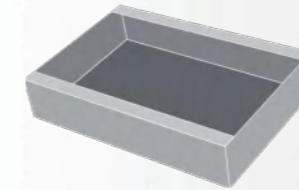

Time cycle comparison
Bending time necessary to realize this 6 bend box-only machine time



Genius Plus Hydraulic
180mm/s



EuroMaster Hybrid
200mm/s



eB Ultra
100% Electric
180mm/s



NO →

- OIL
- NOISE
- HYDRAULIC
- MAINTENANCE
- CYLINDER DWELL TIME

Machine LED status®

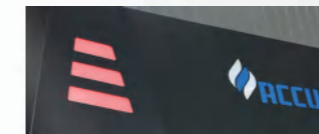

— E-Brake OFF — Reset OK

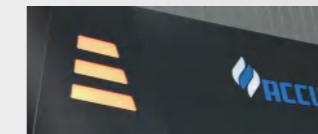

— E-Brake ON — Reset OK

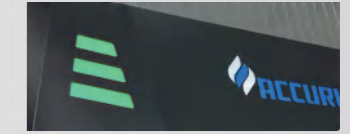

— E-Brake ON — Reset OK — DNC OK

100% FULLY-ELECTRIC SERVO TECHNOLOGY

The result a highly precise, reliable, and high-speed production system coupled with energy efficient and noise-reduced operation.



ACCURL GREEN

ACCURL promotes a friendly environmental policy incorporating in all its models functions that drive sustainability.

SERVO 200-45

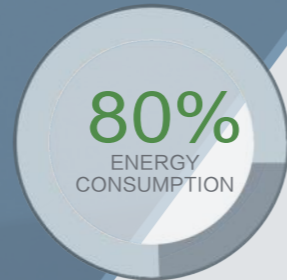

SERVO ELECTRIC TECHNOLOGY

The eB Ultra Series ball screw press brake is driven by an AC servomotor and ball screw drive mechanism. It maximizes productivity with high speed ram and high precision repeatability(0.001mm). This drive method is superior to all other electric/hydraulic performance and is quiet in operation.

/ COMPARISON

The purpose of each option is to get the return that is higher than its cost.



Maximum stamina!
It bends and bends and bends



Lower energy consumption!
Quality / Silent working mode



Faster & more efficient!
Speed / 100% electric servo drive



More faster-on-time!
Save time and costs.....

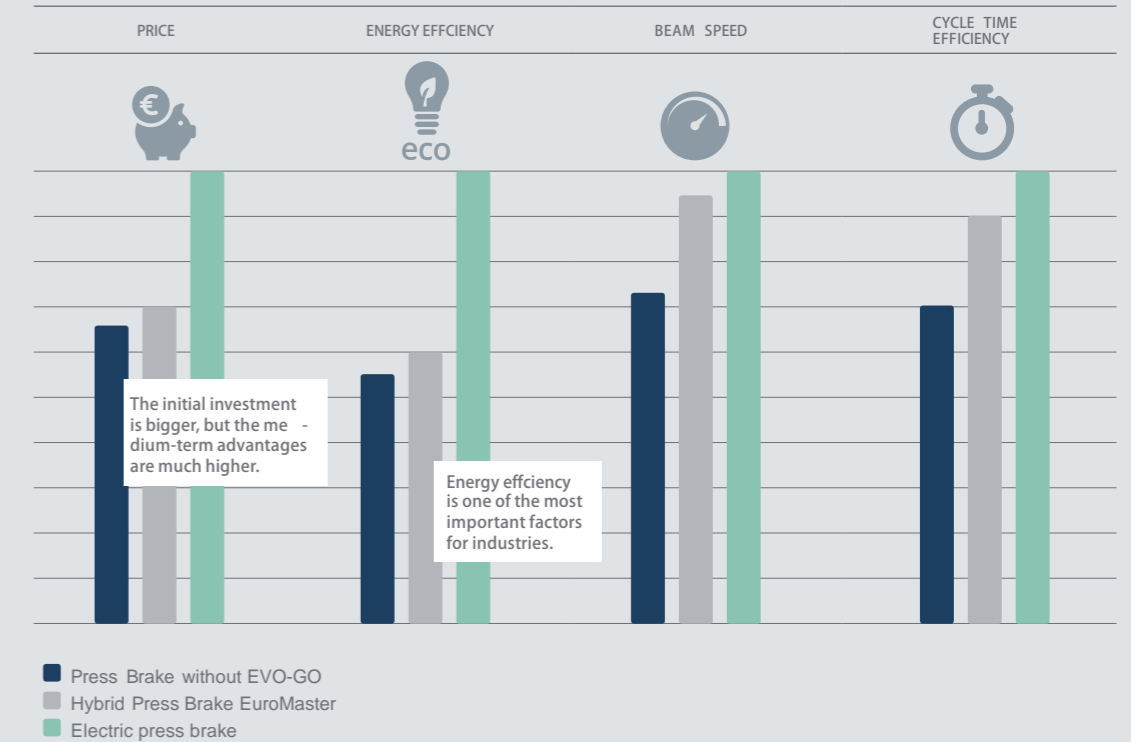

THE "GREENER" COMPETITIVENESS:



- Energy saving
 - 85% lower consumption than hydraulic brakes on an average.
- Productivity
 - Thanks to the high dynamic electro mechanic drive system and "IRIS" safety 55% shorter cycle times on an average.

EVERYTHING WITH ONE click in 3 steps. 100% automated

Optional item FABLE is an acronym of Fully Automated Cut & Bend BundLE and the operator has to set only the initial parameters: FABLE software and algorithms will handle the entire process in a fully automated way, including unfolding.

FULLY IN 3D,CUT BEND THE SHEET METAL



Job tracking add-on

Record and monitor the production\manufacturing process\flow
Store all parts, tubes, daily jobs, SubNests.Sort and filter all the data, and search using complex search queries.
Manage and monitor material consumption and usage efficiency

©Optional*

FABLE IN ACTION: 1,2 e 3. UNFOLDED,CUT AND BEND

ACCURL. Claim For 3D Unfolding

Consisting of a suite of outstanding applications,ACCURL.CLAIM allows you to fully control alle the phases of the creative process, converting ideas into technical drawings ready to be sent to the sheet metal working software.

ACCURL. iCut Nesting For Cutting

With ACCURLiCut software is designed to allow you to achieve the best cutting results, saving material, reducing time & making things easier for the operator, thanks to the high level of automation.

ACCURL. iBend Offline For Bending

Powerful and reliable, create or import geometric details in a moment from any other design platform, automatically optimizing their profiles and optimally preparing them for subsequent processing.

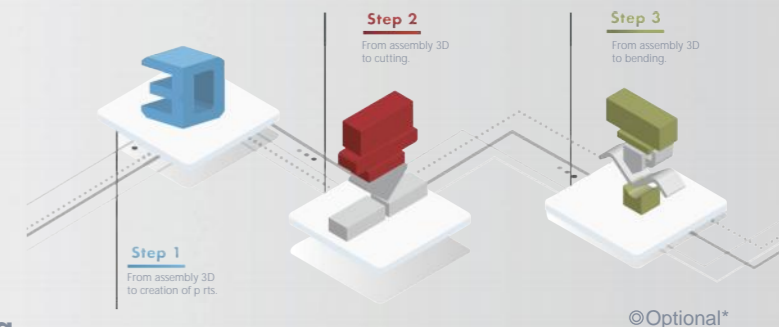

JopTRACK For Shop Management

For every 4 main phases of metal sheet cutting (quotation and order confirmation, order elaboration and warehouse checking for production) the JobTRACK system by ACCURL offers the more suitable software able to support at best the workforce in the relevant decisions and schedules.

STEP 1

From offer request to the order confirmation. Rapid and efficient.

STEP 2

The Production Manager open the internal order issued by sales dept. and he creates a list of works to elaborate in the production dept.

STEP 3

Order Working
The machine is ready. The operator checks nesting and start the machine.

STEP 4

Warehouse Check for the production
From the Production Manager to the warehouse's workers. It's sent the request to prepare the necessary materials for the production with real-time updates of stocks.

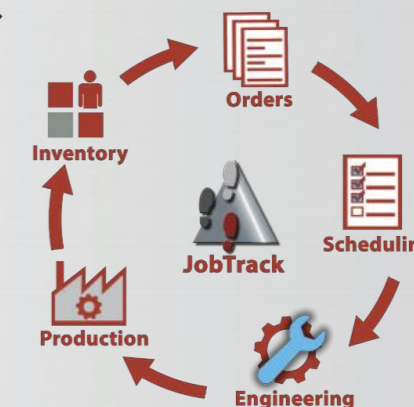

iBend OFFLINE 3D-SOFTWARE*

Production preparation in line with press brake user friendliness:
ACCURL® iBend 3D is an application for programming and simulating CNC press brakes to maximize production resources.

ACCURL.iBend

Offline 3D press brake
simulation by Accurl

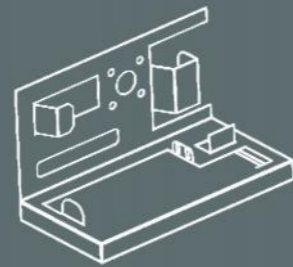

iBEND OFFLINE 3D SEQUENCING AND SIMULATION SOFTWARE

ACCURL iBend enables offline generation of bend sequences and tooling setups, with dynamic 3D simulation for checking collisions of the part with tools, fingers, and machine components.

ADVANTAGES: ACCURL iBEND ENHANCES YOUR PRODUCTIVITY:

- Direct part transfer from SolidWorks, Solid Edge, and Inventor
- Importing and unfolding of IGES and STEP 3D parts
- Importing and folding flat DXF/DWG parts with layer filtering
- 3D simulation of the bending process with collision detection
- Faster design-to-production times with automated features
- Offline programming means minimal machine down-time

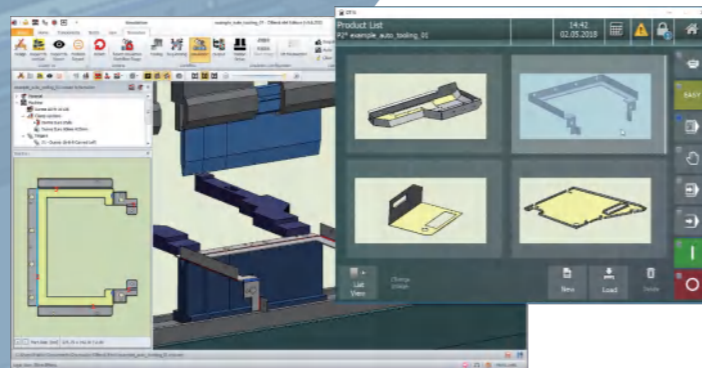

BEND SEQUENCE SELECTION:

ACCURL iBend automatically calculates multiple bend sequences, taking into consideration:

- Collision avoidance
- Tool segment availability
- Heel tools for over-hanging flanges

©Optional*

SETUP REPORTS

The iBend comes with real-time, **automatic 3D simulation**, presenting a realistic visualization of the bending process. and the simulation helps you to create an error-free process, producing NC code or a bending report.

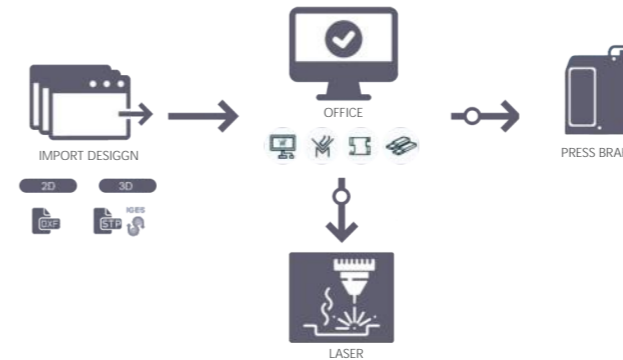

ADVANTAGE

- Bend sequence instructions
- Tool information and tool setup details
- Product handling
- Bend-by-bend graphics
- Bend sequence instructions
- Flat view with the bend sequence
- You can generate your report files in several formats: PDF, DOC, RTF, XLS\XLSX, XML, CSV, and RPT

3D SIMULATION AND COLLISION DETECTION

Automatic simulation and collision detection for part, fingers, tools, and machine:

ADVANTAGE

- Detect collisions between all moving elements
- Visualize bending (overbend, springback) realistically
- Simulate operator part handling
- Simulate the bending sequence with the full machine configuration in 3D-fingers, tools, part, and machine

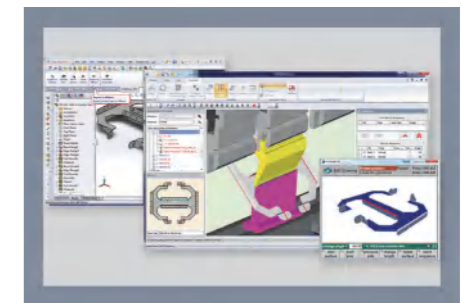

EFFICIENT TOOL SELECTION

ADVANTAGE

- availability of tool geometry and segments
- Bend radius
- Maximum force
- Collision avoidance
- **Full support for hemming:**
 - Specify default hemming tools for automatic selection
 - Default and editable Pre-bend angle.



Press brake bending...

ADVANCED SAFETY

CE Safety Regulations require the application of an Optical Safety Guard (OSG) when operating at closing speed



ANGLE MEASUREMENT

Automatic angle measurement and automatic correction of the bending angle

©Optional*

OPTICAL PROTECTION TECHNOLOGY

The IRIS System safety equipment by LaserSafe represents the most advanced safety solution for press brakes. In terms of productivity and protection level. Its unique features increase the competitiveness of the eP-Press:

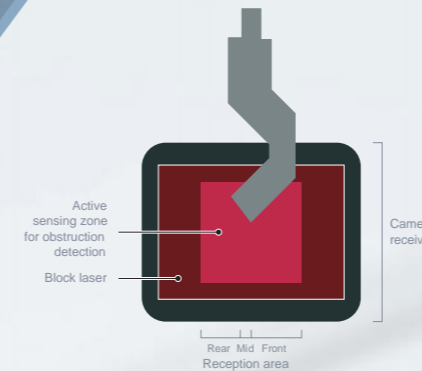

Applies to IRIS and IRIS Plus

IRIS TO MAXIMIZE SAFETY, PRODUCTIVITY AND TOOL CRASH PROTECTION:

- Faster cycle times
- Speed change at 2 mm above material
- Ultimate Operator Safety
- Security against tooling damage
- Full Integration in the CNC System
- Automatic Alignment
- Angle measurement option

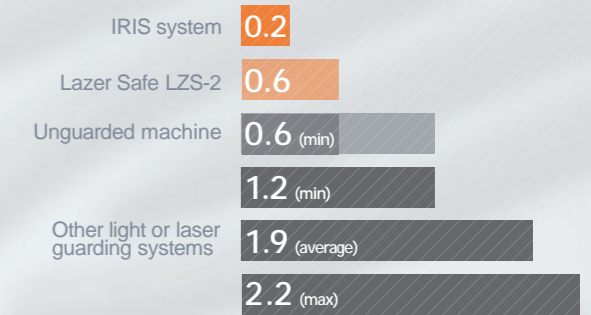

Comparison time in slow speed closing (seconds per cycle)

ANGLE CONTROL PROCESSES

These are two examples of angle control processes that can be implemented in the CNC system through the development of supporting software.

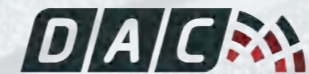

DYNAMIC ANGLE CONTROL • Dynamic Angle Control uses real time angle data plus the recorded spring back value to automatically and accurately control the bending depth. The dynamic angle control is a high speed process that ensures accuracy and consistency between parts with no delay to the bending operation.

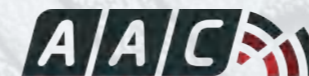

ACTIVE ANGLE CONTROL • Active Angle control is a highly accurate angle control process that calculates spring back for each individual bend, then controls the bend depth with Live Angle Bending to achieve the correct angle.

	IRIS INTEGRATED REAL-TIME BENDING SYSTEM	IRIS PLUS INTEGRATED REAL-TIME BENDING SYSTEM
Optical protection functions	•	•
Optical imaging functions	•	•
Maximum recommended optical range	8 metres	4.5 metres
Optical sensor		
Camera	Digital Image Sensor	Digital Image Sensor
Frame rate / frequency	10ms/100Hz	10ms/100Hz
Data resolution (sensor)	-	0.01 degrees
Measurement technology		
Type	Integrated High-Speed Image Processor	Integrated High-Speed Image Processor
Memory depth	-	Records up to 10 seconds (1000 images) of bend data per cycle.
Measurement accuracy	-	Up to +/- 0.25 degrees
Measurement rate	-	10ms/100Hz (synchronised with frame rate)
Imaging technology		
Bend Speed Management*	•	•
BendVision*	-	•

*Supporting software development is required for the CNC system.

STATE OF THE ART FLEXIBLE SOLUTIONS

Everything under control

DA-60S
Touch

**STATE-OF-ART FUNCTION
COMPLETE**

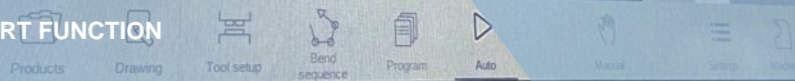

The DA-69S offers 2D as well as 3D programming that includes automatic bend sequence calculation and collision detection. Full 3D machine set-up with multiple tool stations giving true feedback on the product feasibility and handling.

DA-60S - SERIES 3D GRAPHICAL CONTROL

The control operation, based on state-of-the art industrial touch screen technology, gives access to the proven renewed Delem user-interface and enables direct navigation between programming and production. Functions are directly located where you need them, offering optimised ergonomics throughout the application.

HARDWARE SPECIFICATIONS

- New ergonomic, premium, rugged design
- Linux based OS, improving performance
- 24" HD widescreen + industrial PCT touch screen technology
- New high performance platform, using latest industrial standards
- Large OEM-panel for switches, signals, etc.
- Easy access to all connections

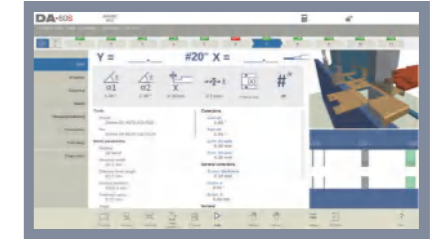

DA-69S FEATURES:

- 3D and 2D graphical touch screen programming mode
- 3D visualisation in simulation and production mode
- 24" high resolution colour TFT
- Delem Modusys compatibility (module scalability and adaptivity)
- USB, peripheral interfacing
- Support for Industry 4.0 connectivity (OPC-UA optional)
- Shop floor control, Job list functionality
- Open system architecture
- Sensor bending & correction interface
- Profile-S 3D offline software



©Optional*

DD-60S FEATURES:

The DD-60S 2nd monitor enhances press brake control with software integration, empowering operators with real-time ERP access for efficient production planning, minimizing the need for separate workstations, and optimizing workflow.

- 24" high resolution colour TFT
- Industrial grade touch screen functionality
- HDMI interfacing
- 2x HDMI interface
- Proprietary switch function from CNC
- USB, peripheral interfacing, automatically switching
- 2x USB, switching with source
- 1x USB, direct

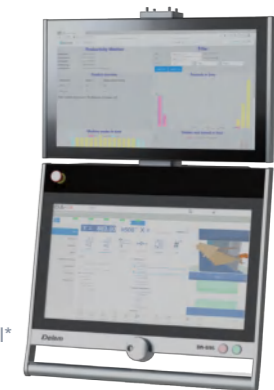

©Optional*

WILA NEW STANDARD TOOL HOLDERS SYSTEM

The New Standard Tool Holders (Clamping, Crowning and Bottom Tool Holders) make it possible to change tools very quickly. When combined with our state of the art New Standard Tooling they also provide maximum accuracy flexibility, durability and safety



UPB / ES
Premium / Pro
HC / MC
HD
SL
STL

EFFICIENTLY CHANGE YOUR PRESS BRAKE TOOLS

ADVANTAGE:

- Innovative and extremely fast clamping systems
- Tailored to each individual press brake
- Top-quality materials that ensure a long life
- Horizontal and vertical change of tooling
- Available with hydraulic, pneumatic or manual clamping

WITH
PATENTED
SELF-LOCKING
PERFORMANCE®



©Optional*

POWERFUL SELF-LOCKING® PERFORMANCE

Tools can be locked and released extremely quickly using air pressure, while clamping force is provided by our patented Self-Locking mechanism. This unique combination results in a much faster tool change and increases your productivity in the long run.



PNEUMATIC CLAMPING WITH WILA NEW AIRPOWER SERIES

- Now available:

The complete range of WILA's pneumatic tool holders, top and bottom, Pro and Premium. Speed up operations and tool changes— and maximize productivity.

LEAN, CLEAN AND GREEN

- No oil, no hydraulics
- No pressure booster needed (6-8 bar will do)
- Ultrafast clamping for more productivity
- Lower operating costs
- For top and bottom tooling
- Cleaner, more sustainable
- For new and existing press brakes



New Standard Clamping

- Innovative and extremely fast clamping systems
- Equipped with Guards
- Horizontal and vertical change of tooling
- Can be installed on any press brake thanks to the UPB concept
- Suitable for New Standard top tools
- Available with hydraulic, pneumatic or manual clamping



New Standard Crowning

- Tailored to each individual press brake
- Top-quality materials that ensure a long life
- Perfect compensation for deflection, resulting in a consistent bend angle over the entire length of the machine
- Using a range of patented adjustable wedges known as WILA Wave Wedges
- Can be operated CNC-controlled or by hand



New Standard Bottom Tool Holders

- Ideal for press brakes that do not require a crowning system, or for press brakes with a crowning system already incorporated into the lower beam
- Compact design with fully integrated clamping system for dies
- Available with hydraulic, pneumatic or manual clamping

INTERNATIONAL BENCHMARK FOR PRESS BRAKE TOOLING

ACCURL® press brake tools are made from WILA in Netherlands, are well polished and hardened. & ACCURL has wide range of bending tool solutions, such as 1V and multi-V lower tools and different upper tool solutions.

NEW STANDARD WILA TOOLING

WHY CHOOSE WILA NEW STANDARD TOOLING

- Fast and safe tool changes
- Self-seating and aligning
- High quality finish, maximum precision
- Long tool life, designed for flexibility
- Hardened contact surfaces 60HRC

©Optional*

PRESS BRAKE PRODUCTIVITY TOOLING FROM WILA:

The WILA tools with Safety-Click® & the E2M® changing system for (heavy) tools, have made the changeover process easier and safer. accuracy and ergonomics are optimally matched to achieve the highest productivity with all tools.

New Standard Premium Tooling:

- All compression and wear areas are fully CNC-Deephardened® to 56-60 HRC for maximum durability
- Extreme precision and bending performance
- High workload and maximum durability
- Uncompromising long-term performance and quality
- Comply with complex requirements and extreme tolerances



Press Brake Tooling



Press Brake Tool Holders



Safety-Clicks



TOOL MANAGEMENT

If you are familiar with lean manufacturing principles, you understand the advantages of efficient tool management. Tools should be stored near the press brake for easy access. You should also be able to identify and enter them into the press brake control quickly and easily. This will save time and help prevent mistakes during changeovers. With proper care, maintenance, and tool storage, WILA Tooling will retain its accuracy for ten years or more.



SMART TOOLING APP

The WILA Smart Tooling App provides instant access to tool data anytime, anywhere. It offers major time savings, error-free tool data entry, and simplified tool inventory management. All WILA New Standard Premium tools feature a unique, scannable code, offering an Industry 4.0 Tool Management solution for digital tool data exchange.

BGA SERIES BACKGAUGE

FAST & ACCURATE WITH CONSTRUCTION

The ACCURL BGA series CNC backgauge to help with all your bending needs – let us help you configure the best solution for your press brake needs.

PERFECT POSITIONING

ACCURL options for back gauge systems and material handling complete the Press Brake

ENTIRELY ACCORDING TO CUSTOMER SPECIFICATION

No matter if 4, 5 or 6 axes, support bracket, sheet support or bending aid – you decide how your press brake will look like. We guarantee that your multi axis press brake can be configured to meet your needs and bending requirements exactly.

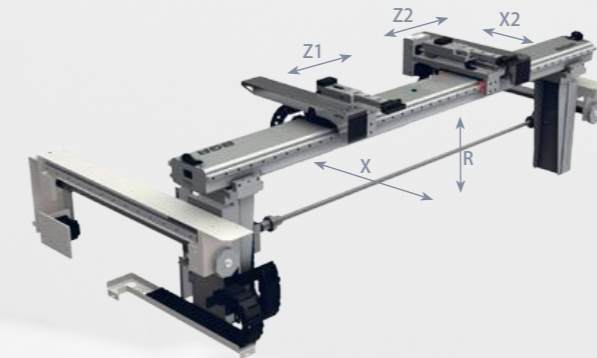

THE ACCURL OPTIONS-YOUR ADVANTAGES:

- Highest precision and dynamics with all back gauge systems – up to 1200 mm/s
- Back gauge systems can be selected according the requirements: 2, 4, 5 or 6 axes
- Time and effort-saving handling thanks to optimum bending aids
- Additional support brackets for light and thin sheet metals

SUPPORTS:

Sheet supports are auxiliary bending accessories. They must be chosen according to the dimensions and weight of the pieces.

Front supports: Support the plate during the front feed

Back supports: Support the plate in the approach to the back gauge

Follower supports: Support the movement of the plate during the bending



ACCURL believe in innovation and continuous improvement. For these reasons, ACCURL has created new servo sheet followers to support the sheet during the bend, avoiding excessive deformation.

- Light solution, easy to move
- AP1 - AP2 CNC-controlled interpolated axes
- Recommended for heavy parts or large thin plate
- bend as closed as 70°
- Load capacity – 160kg or 350kg per support.
- Brush and support shaft dim 350x900 up to 1200 mm

©Optional*



The SPA Thin supports system are installed in the fingers of the back gauge. They can be activated in predefined bending angles and enable the plate to slide until it lies adjacent to the back gauge.

ADVANTAGE:

- Back supports have ball sliders and brushes to protect even the most delicate surfaces
- Load capacity – 30 kg per support
- Best configuration for sheet box bending

©Optional*

CHOOSE AND CONFIGURE YOUR PRESS BRAKE

A territory with a consolidated technological background and the inventiveness of the ACCURL family are the ingredients of the birth of ACCURL. One of the first company to apply Industry 4.0 enters the world of sheet metal bending machines in China by ACCURL.



ACCURL MORE INNOVATION

TECHNICAL SPECIFICATIONS

	Bending length	Tonnage	Throat depth	Beam stroke	Daylight	Fast	Bending	Return (RS)	Back gauge stroke	Motor power	Total length (A)	Total height (B)	Total width (C)	Distance between frames	Aprox. weight	
						Y axis speed					Dimensions					
						mm/s					mm					Kg
eB Ultra 85-25	850	25	120	150	320	220	0~10/30*	230	350	11.2	1450	2050	1180	820	2150	
eB Ultra 105-35	1050	35	200	200	320	220	0~10/30*	230	350	15.2	2150	2280	1550	880	3650	
eB Ultra 125-35	1250	35	200	270	520	210	0~10/30*	220	500	15.5	2150	2450	1550	1080	4300	
eB Ultra 125-45	1250	45	200	270	520	190	0~10/30*	220	500	25.5	2150	2450	1550	1080	4350	
eB Ultra 155-45	1550	45	200	270	520	190	0~10/30*	220	500	25.5	2850	2450	1580	1380	4850	
eB Ultra 200-45	2050	45	200	270	520	190	0~10/30*	220	500	25.5	3050	2450	1550	1880	5750	
eB Ultra 155-60	1550	60	200	270	520	200	0~10/30*	230	500	25.5	2850	2580	1600	1380	6050	
eB Ultra 200-60	2050	60	200	270	520	200	0~10/30*	230	500	25.5	2950	2578	1600	1880	6650	
eB Ultra 255-60	2550	60	200	270	520	200	0~10/30*	230	500	25.5	3550	2580	1600	2380	7250	
eB Ultra 255-80	2550	80	350	270	520	190	0~10/30*	200	600	31.6	3550	2630	1700	2380	7850	
eB Ultra 255-100	2550	100	400	300	550	190	0~10/30*	180	600	31.8	3580	3050	1750	2380	8250	
eB Ultra 305-100	3050	100	400	300	550	190	0~10/30*	180	600	31.8	4650	3050	1800	2450	8850	
eB Ultra 305-130	3050	130	400	300	550	180	0~10/30*	160	600	36.6	4650	3150	1800	2450	9350	

* The second speed is only available for some markets

Content subject to change without notice. V6.18

